

US9258

Hand Dryer Combination

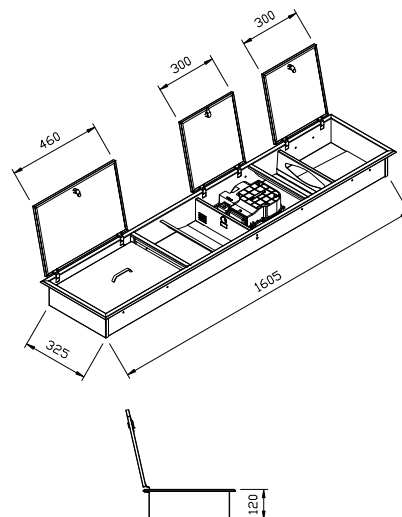
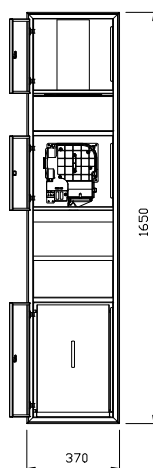

Draw not to scale

Electrical Spec.

Rating Voltage:	AC110V/AC220V
Frequency:	50 HZ - 60 HZ
Rating Power:	1150 W
Motor Type:	Carbon brush motor
Motor Power:	550 W
Motor Speed:	25000 rpm
Heating Type:	heating wrie
Stand-by Power:	2 W

Structural Spec.

Shell Material:	USU304
Shell Colour:	Brushed
Water-proof:	IPX1

Functional Spec.

Switch Type:	Rocker Switch
--------------	---------------

Operating Spec.

Sensor Type:	Infrared diffuse reflection induction
Time-out Protection:	45 seconds
Drying Time:	15 seconds
Air Speed:	53 m/s
Air Amount:	32 L/S
Noise:	72 dBa
Anti-electric shock Rate:	rate I

Shipping Data:

N. Weight (Kg):	17.7
G. Weight (kg):	28.7
Products Size (mm):	1650*370*120
Package Size (mm):	1680*395*170
Hole Digging Dimension:	1610*355*130
pcs/ Wooden case:	1
Volume of Dustbin:	17 L

Certificactes CE CCC GS